

ZUBEHÖR ACCESSORIES

**Gehäusedeckel mit
Flansch und Drosselklappe
Saugseite**

*Housing cover lid with
flange with throttle valve
intake side*

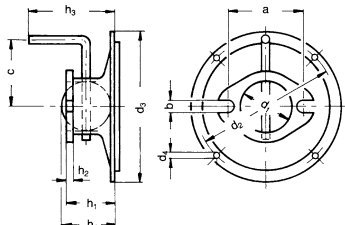

Typ Type	a	b	c	d ₁	d ₂	d ₃
RD 0, RE 0	110	13	94	74	204	215

Typ Type	d ₄	h ₁	h ₂	h ₃	h ₄	Artikel-Nr. Article No.
RD 0, RE 0	4x ø5,8	114	10	158	-	000015

**Schweißflansch für
saugseitige Anschluß-
rohrleitung**

*Welding flange
for pipe connection
on intake side*

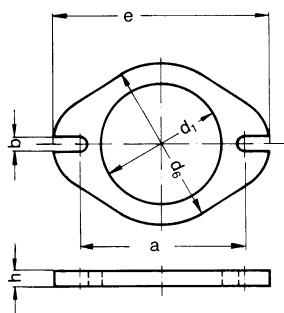

Typ Type	a	b	d ₁	d ₆	e	h	Artikel-Nr. Article No.
RD 0, RE 0	110	13	78	100	145	6	011925

**Feinfilter Saugseite
Fine filter intake side**

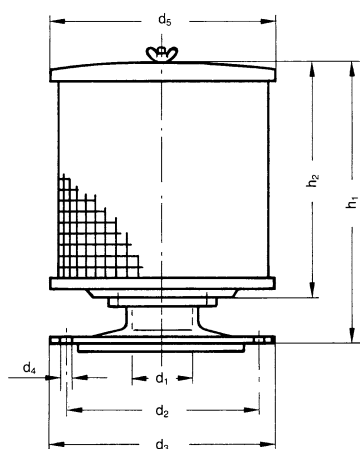

Typ Type	d ₁	d ₂	d ₃	d ₄	d ₅	h ₁	h ₂
RD 0, RE 0	74	204	215	4x5,8	148	187	133

Typ Type	Filter Filter	Ersatz- filtermatten Spare filter tissues	Abmessung Ersatzfilter- matte Dimension Spare filter tissues
	Artikel-Nr. Article No.	Artikel-Nr. Article No.	
RD 0, RE 0	009098	008636	15x123x425